



AIS SART

Rescue Beacon

SR500



INSTRUCTION MANUAL

CONTENTS

OVERVIEW	1
MOUNTING	2
Mounting Procedure	2
EMERGENCY PROCEDURE	2
Deployment Process	2
Activation Process	3
Emergency Mounting Process	3
DEACTIVATION PROCESS	4
SELF-TEST	5
MAINTENANCE	6
Routine Checks and Cleaning	6
Red Protection Cover Replacement	6
Battery Replacement	6
PRODUCT SPECIFICATIONS	6
DIMENSIONS	7

OVERVIEW

The SR500 is a single use device. Only remove the RED anti-tamper cap if you intend to use the SR500 in a real emergency. Once activated, and before returning it to storage, service maintenance and battery replacement is required.

Figure 1

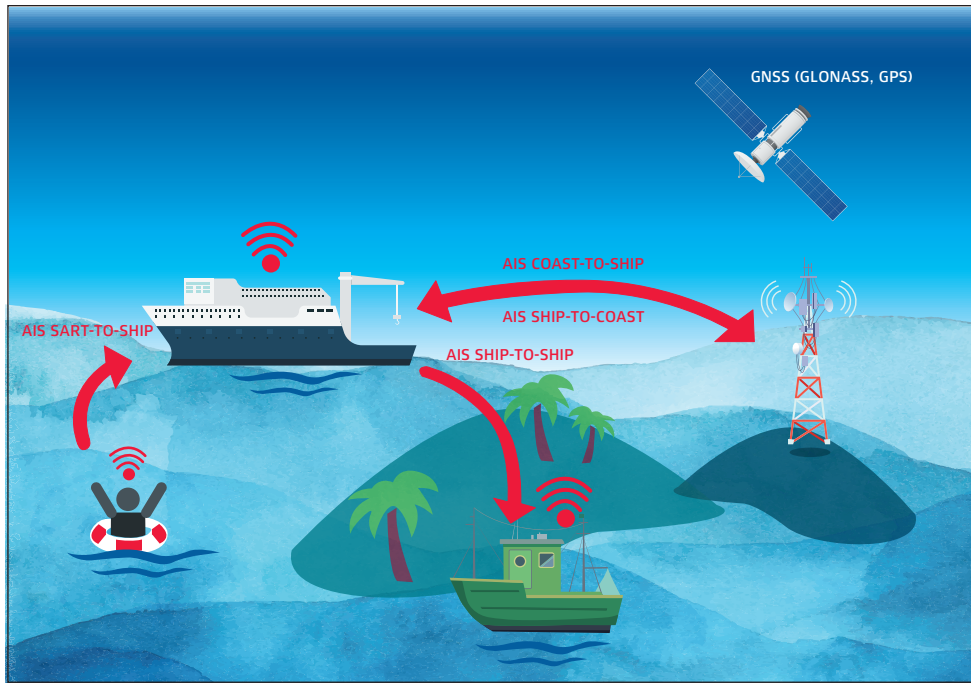

The SR500 is packed in a buoyant carry bag with carry strap. The carry bag contains the SR500 main unit, a 1-metre telescopic extension pole and 10-metre buoyant lanyard. The carry bag may be wall mounted using the wall mounting bracket provided.

The carry bag protects the SR500 while it is stored or carried onto a survival craft. When assembled and ready for deployment, the main unit remains buoyant and waterproof. It is tested to remain functional to a depth of 10 metres in water.



Figure 2

When in its carry case the SART can be dropped from a height of 20 meters. The SR500 control panel has fluorescent backlighting that increases its visibility in reduced lighting conditions.

The ON button is protected from accidental activation by a single use anti-tamper cap. When activated a dual colour red/amber LED indicator provides a real-time status indication and flashes the SOS Morse code sequence. The SR500 is delivered with the items as illustrated in Figure 3.

Item	Description	Quantity
1	SR500	1
2	Carry bag	1
3	1m extension pole	1
4	10m buoyant lanyard	1
5	Wall mounting bracket	1
6	Screws M4x20	2



Figure 3

MOUNTING

When mounting the SR500, consider the following when selecting a suitable mounting position:

- Choose a position adjacent to the vessel's bridge for easy access in an emergency
- Choose a position at least one metre away from compass equipment
- Choose a location away from the effects of extreme weather and other environmental factors
- Choose a location that allows the device to be easily removed from the bracket

Mounting Procedure

When mounting the SR500 use the wall mounting bracket supplied. It is designed to mount on a flat surface using two fixing points and the two marine grade stainless steel screws supplied. Fix the wall mounting bracket to the vessel's wall using the screws.

Check that the mounting surface is suitable. Position the mounting bracket in the chosen position and mark the positions of the mounting slots on the wall using the bracket as a template. Fix the bracket to the wall using the two screws.

Place the SR500 carry bag rear pockets over the bracket hooks and push the carry bag into place.

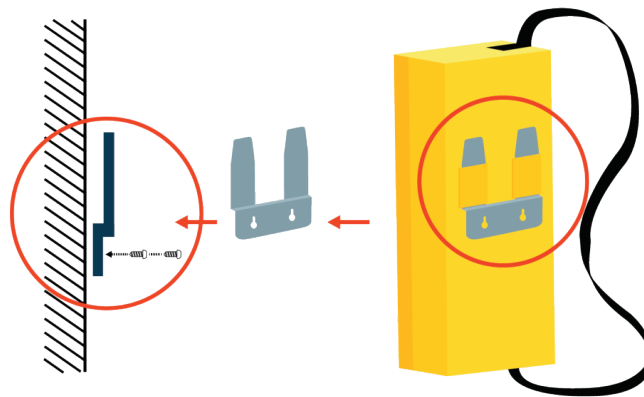

EMERGENCY PROCEDURE

The emergency procedure has three major steps: deployment, activation and emergency mounting.

Deployment Process

To deploy the SR500:

- 1) Remove the carry bag from the wall bracket
- 2) Take the carry bag into the life boat
- 3) Open the carry bag and remove the SR500, the extension pole and the buoyant lanyard
- 4) Fit the extension pole into the SR500 and screw it into the device
- 5) Remove the bottom cover and extend the pole up to 1 metre

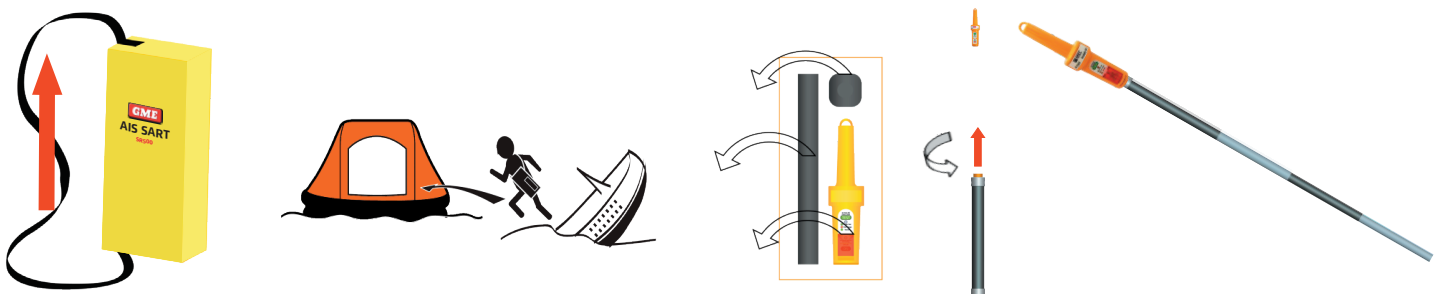

Activation Process

To activate the SR500:

- 1) Pull and break the red anti-tamper cap to reveal the activation panel.
- 2) Press and hold the ON button for two seconds:
 - a. The amber LED flashes during GPS acquisition.
 - b. The green LED flashes while GPS position is fixed.

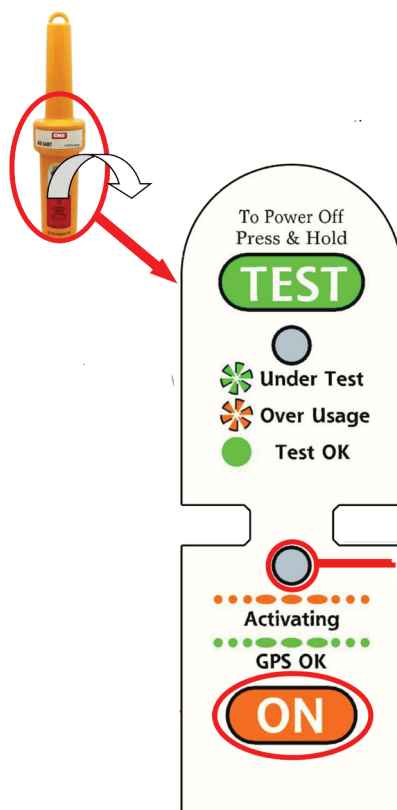

Note:

- The GPS receiver is activated (cold started) when the ON button is pressed and held for two seconds. The amber LED flashes initially then changes to a green LED flash when the GPS position is fixed
- The LED flashes the SOS Morse code every 30 seconds
- The SR500 will transmit SRM (Safety Related Message) with the latest GPS fixed position every 1 minute
- The anti-tamper cap cannot be replaced once removed

Emergency Mounting Process

There are two methods that can be used to mount the SR500 in an emergency.

To mount the SR500 using emergency mounting method 1:

- 1) Release the buoyant lanyard from the top of the SR500.
- 2) Position and fix the SR500 inside the life boat at a minimum height of one metre.



To mount the SR500 using emergency mounting method 2:

- 1) Fit the extension pole into the SR500 and screw it into the device.
- 2) Pass the extension pole through the life raft canopy port hole and secure the pole in a vertical position.

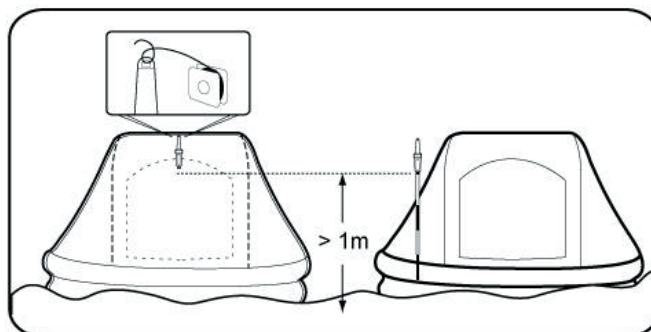

Note:

- Tying the buoyant lanyard between the device and the life boat can prevent losing the device accidentally
- Keep the device at least one metre above sea level to allow efficient operation

Deactivation Process

To deactivate the SR500:

- 1) Press and hold the TEST button for three seconds to initiate deactivation.
 - 2) Keep pressing and holding TEST until the ON LED stops flashing.
- The SR500 is deactivated.

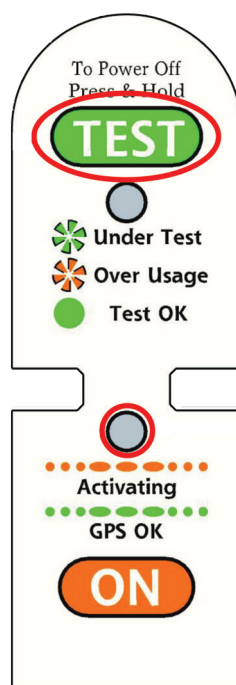

Note:

When deactivated all the LEDs are off. If LEDs are still flashing press and hold the TEST button again for three seconds to deactivate the device.

SELF-TEST

It is recommended to self-test the SR500 every six months. A test transmission is sent that is visible to all AIS (automatic Identification system) users in range. Testing success depends on the GNSS position acquisition. Testing must be carried out in the open and under an unobstructed sky.

In test mode, the SR500 transmits a unique 9-digit digital ID number and the latitude and longitude coordinates. The AIS receiver shows “SART TEST” when the SR500 is transmitting in test mode. If the SR500 is transmitting in active mode the AIS receiver shows “SART ACTIVE”.

Remove the SR500 from the carry bag and fit the device onto the mounting pole. Hold the SR500 up in clear view of the sky to maximise GNSS position acquisition.

To begin the self-test, press and hold the “TEST” button for three seconds. The LED flashes green or amber. The LED should flash green within two minutes of the GPS/GNSS position being fixed. If it takes longer than five minutes for the LED to flash green the position may not be fixed. Move to a new location that has a clearer view of the sky to obtain a better result.

Note:

If the LED flashes amber the SR500 has already previously been activated or self-tested more than the maximum 100 times.

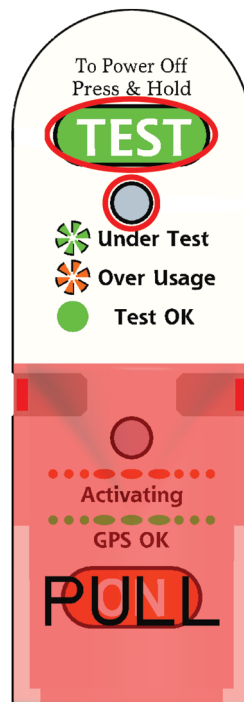

Flash	Description
Green	AIS SART is testing – no over usage warning
Orange	AIS SART is testing – over usage warning
1 long green	AIS SART transmission complete – light turns off automatically after long green flash

Note:

Do not hold or cover the GPS Area while the device is active or while self-test is being performed to avoid problems with fixing the GPS position.

MAINTENANCE

Routine Checks and Cleaning

It is recommended that routine checks are performed to verify that the battery expiry date has not passed, that there is no damage to the device, the wall mounting bracket, the carry bag, the extension pole or the buoyant lanyard. Clean the SR500 using only fresh water then wipe it dry with a soft cloth.

Note:

Do not use chemicals to clean the SR500 or the accessories.

Red Protection Cover Replacement

The SR500 red protection cover is broken when the device is activated. The SR500 is a single use device. Replacement of the red protection cover must be performed by an approved service agent.

Battery Replacement

The battery needs to be replaced every six years, when the expiry date is passed or when the SR500 has been activated. Check the battery expiry date regularly to ensure the device is working properly. Lithium batteries require special disposal procedures. Please contact your approved service agent to replace your battery.

PRODUCT SPECIFICATIONS

APPLICABLE STANDARDS

IEC 61097-14 Ed.1 (2010)

IEC 60945 Ed. 4 (2002) incl. Corrigendum 1 (2008)

IMO Resolution MSC.246 (83)

ITU-R M.1371-5 (2014)

VHF TRANSMITTER

Operating Frequency	AIS 1, 161.975MHz AIS 2, 162.025MHz
Data Rate	9,600 bps
Bandwidth	25 KHz
Power Output	1W EIRP
AIS Message Type	Message 1, Message 14
Modulation	GMSK
Antenna	Integrated by PCB

GPS RECEIVER

Receiving Channels	48 Channels
Acquisition Sensitivity	(-)159 dBm
Tracking Sensitivity	(-)159 dBm
Position Accuracy	< 2.5 m Autonomous & SBAS

BATTERY

Type	Primary Lithium (Not Rechargeable)
Operating Life	96 Hours Minimum
Storage	6 years
Service	Replaceable *

*Please refer to Page 6 for Replacement

CARRY & MOUNTING

Carry Bag	
Wall Mount	

ENVIRONMENT

Operating Temperature	-20°C~55°C
Storage Temperature	-30°C~70°C
Waterproof	Immersion to 10m
Buoyancy	Floats
Exterior Finish	Highly Visible Yellow
Compass Safe Distance	Standard Magnetic – 0.60m Steering Magnetic – 0.40m

PHYSICAL

Max Diameter (Main Body)	70 mm
Length (Main Body)	300 mm
Weight (Main Body)	283 g (Battery Included)
Length (Pole)	1050 mm (Extended)
Weight (Pole)	300 g
Weight (Storage Package)	1.08 kg

DIMENSIONS

SR500 Front View

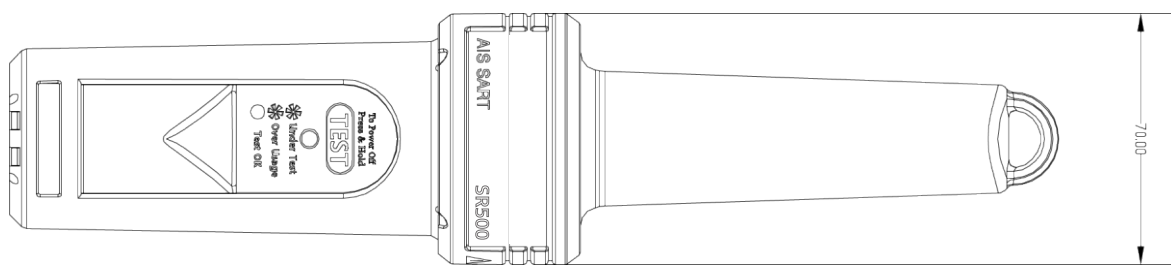

SR500 Side View

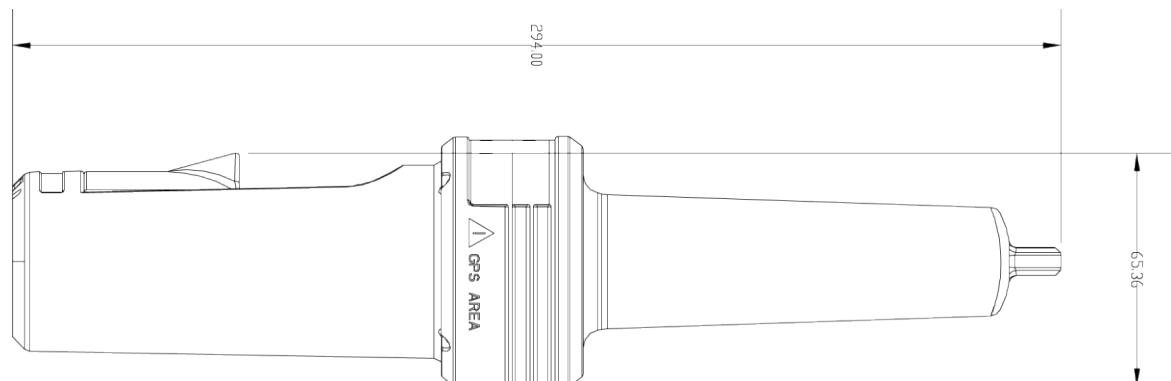



gme.net.au

GME Pty Ltd

Head Office: 17 Gibbon Road, Winston Hills NSW 2153, Australia. T: +61 (02) 8867 6000

New Zealand: PO Box 58446 Botany, Auckland, 2163, NZ. T: +64 (09) 274 0955 Email: enquiries@gme.net.au

Drawing Number: 52144-1 Part Number: 311140